

# Mess Handbook



*A guide for the  
Cadet Mess Dinner*

## **General**

The following has been taken from the *NOTC Manual of Canadian Naval Etiquette*, Edition One, January 1990.

Tradition remains to this day one of the prime ingredients in naval *esprit de-corps*. Over the course of centuries, the Royal Navy acquired numerous customs and usages which the Canadian Navy has readily assimilated.

Mess Dinners are usually hosted by the Officers Wardroom at least once a year. For the information contained in this handbook, it is assumed that the Wardroom is the official host. However, it should be noted that the Chief and Petty Officer's Mess may also host this event.

Some traditions and protocols detailed may be specific for the unit only.

## **President**

The President of the Mess is appointed by the Commanding Officer and is typically the Executive Officer or First Lieutenant.

S/He is responsible for maintaining good order, conduct, formality, discipline, timings, and fluidity in the mess.

The president is in absolute charge of the mess regardless of rank, branch or seniority. He/She may levy fines or take any other action he/she deems necessary to maintain discipline.

No person in the mess may be seated, begin eating, or toast prior to the President.

## **Vice-President**

The President of the Mess assigns a Vice-President for each table in his/her Mess.

They are responsible for:

- Speaking for their table;
- Bring infractions of the opposite table to the attention of the President;
- Defending their table when an accusation has been made against one of his/her diners;
- Ensuring their diners are conforming to the rules and orders of the Mess;
- Directing questions to the President; and
- Anything else deemed necessary and appropriate by the President prior to beginning of the mess function.

## **Captain**

In a navel mess it is usually customary for the Captain not to serve as the President of the Mess. The XO assumes the position of President and always extends an invitation to the Captain for attendance at all mess functions.

The Captain will sit at the head table in a prominent position close to the President. Proper respect and dignity shall always be shown to the Captain of the ship, regardless of the role s/he assumes for the evening.

## **Honourary-Captain**

It is in Naval Custom for the youngest member of the Ship's Company to be bestowed the position of Captain for the evening.

The Captain shall sit next to the President. S/He is always treated as an honoured

guest of the President of the Mess.

## **Guest**

Guests are invited into the mess by the President. Each person invited are usually seated at the head table and briefed on the rules of conduct prior to sitting.

## **Member/Crew**

Officers (excluding the XO and CO) and cadets are considered general members of the mess.

Each member shall follow the rules and code of conduct for the mess.

## **Wearing Apparel**

Civilians should wear business-formal attire.

Traditionally, naval officers should wear a hand-knotted bow tie.

Cadets wear their ceremonial uniform with medals (less lanyard).

Headdress, webbing, gaitors, and nametags are not permitted in the mess.

## **The Gavel**

The President and Vice-Presidents shall have gavels to conduct business. The member shall rap their base to gain the attention of the mess.

## **Arrival**

The time of arrival at a dinner is always set out in the invitation. If no time is noted for arriving at the dinner then arrival no later than 15 minutes prior to sitting is always the rule.

NEVER BE LATE.

Diners will arrive dressed and ready for the event. Members and guests appearing out of rig shall not be allowed to dine.

## **Entry**

When the mess is ready to begin the function, everyone stands behind their seats and awaits the arrival of the Head Table.

If a band is present, or a sound system is available, the head table enters to "*Heart of Oak*"

The President, accompanied by the head table, enters into the mess.

The President, Commanding Officer, Captain, and guests take their places behind their seats. No one should sit before the President has taken his/her place.

## **Seating**

Members sit according to the seating plan posted outside the dinning hall/room.

Members of the mess sit from the left side of their set and stand from the right side.

If a male member is sitting next to a lady, then the gentleman should seat her before seating himself.

Do not touch anything on the table until after the first Grace.

There should never be a vacant seat between two diners. If too many places have been laid, the diners should close in towards the vice-president, keeping the numbers on each side of them and at the table as even as possible.

**Commencement** When everyone is seated, the senior steward reports to the president, "*Officers seated, Sir/Madam/Ma'am*".

The president taps the table for silence.

If there is no chaplain present, the president may designate any member to carry out this duty.

The prayer is "*For what we are about to receive, thank God*". The prayer after the meal is: "*For what we have received, thank God*".

**Rules of Order** As soon as the president has tapped the table for grace, the following rules are rigidly enforced:

- a. Without the president's permission, no one may
  - (1) Enter and seat themselves at the table,
  - (2) Leave the table,
  - (3) Return to the table,
  - (4) Read (except the menu and musical program),
  - (5) Write,
  - (6) Have a second helping of any course, or
  - (7) Speak to anyone not dining
- b. All diners wishing to communicate with the President must do so through the table Vice-President.
- c. No diner may do the following:
  - (1) Commence a course before the president,
  - (2) Utter an oath or use foul language,
  - (3) Place a bet or wager,
  - (4) Discuss political or other controversial subjects,
  - (5) Talk shop,
  - (6) Mention a specific sum of money, or
  - (7) Propose a toast.
- d. If a diner has been granted permission to sit down late or return to the table, he/she continues with the course then being eaten or served, unless the president gives him/her permission to eat the course which was missed.
- e. Whenever the president or vice-president summons attention, there must be complete silence until they have finished speaking.

**Order of Serving** When the first course arrives it will be served from your **left**. The plates will be taken from the rights.

No dish is ever removed until the last diner has finished eating the course then being

served.

According to naval tradition it is customary to break bread as opposed to cutting.

If dessert is to be served, dessert plates, knives and forks are also placed on the table.

When the last course has been eaten, the stewards clear the table of everything (except the table decorations and port glasses) and sweep up the crumbs.

When the table is cleared, the senior steward reports to the president, *"Table cleared, Sir/Madam/Ma'am"*.

The president taps the table for silence and grace is said as before; the customary prayer being: *"For what we have received, thank God"*.

### **Port for the Loyal Toast**

Port is the name of a drink used for toasting in a mess. An actual drink called Port exists, however, in a cadet mess it is typically replaced by grape juice. If a diner does not wish to take port for the Loyal Toast, s/he may do so with water.

### **Passing the Port**

The port decanters are then placed on the table. One for the President and one for each Vice-President.

When the decanters are all placed on the table, the senior steward reports to the president: *"The port is ready to pass, Sir/Madam/Ma'am"*.

The President gives the order, *"out stoppers"*. The stoppers are taken out and passed to the person of the left.

In a naval mess the decanters should be slid to the left and never leave the table. Passing the port along the table was implemented for practical reasons, as lifting a heavy decanter off a table in a moving ship might mean the table coming up quickly under the decanter and potentially losing the rest of the precious port

If a lady is sitting on the left it is customary to ask the lady if you may pour for her. This must only be done after you have filled your own glass.

The last persons to receive the Port are the Mess President and Vice-Presidents. After they pour their Port, stoppers are placed back onto the decanters.

No one may touch his/her port until the Loyal Toast has been proposed.

When the port has been passed and all decanters have reached their destination, the senior steward reports to the president, *"The port has been passed, Sir/Madam/Ma'am"*.

### **Toasts**

In a Naval Mess, whether on board or on shore, no member shall stand to give a toast or a reply. Only if a naval member is in an Army or Air Force Mess shall they stand for a toast.

No toast may be offered before the Loyal Toast followed by the Toast of the Day.

Remember: Do NOT drink all the Port for the first two toasts as there may be more to come. You are not allowed to refill your glasses until after the President authorizes “*out stoppers*”

### **Loyal Toast**

The president taps the table for silence and says: “*Mister/Madam Vice, the Queen*”. This is directed to the Senior-VP.

The vice-president responds, “*Ladies and Gentlemen, the Queen*” or “*Madames et Messieurs, La Reine*”

All diners raise their glasses and repeat “*The Queen*” or “*La Reine*” and drink the toast.

It is customary in a Canadian Forces mess to make the toast in one of the official languages and the reply done in the opposite language.

### **Toast of the Day**

There is no official record of the original Toasts of the Day. However, these were popular in Nelson's day, although they have been amended to adjust to changing times and situations:

**Monday** - *Our Ships*

**Tuesday** - *Our Sailors*

**Wednesday** - *Ourselves*

**Thursday** - *Our Navy*

**Friday** - *Our Nation*

**Saturday** - *Our Families*

**Sunday** - *Absent Friends*

### **Additional Toasts**

After the two toasts have been made the President may open up the floor for the diners to make toasts.

Toasts should be meaningful, honest, and relevant to the function of the mess.

### **Removal of the Port**

The president may order the port removed after the toasts are drunk, but it is customary to sit over it and to pass the decanters at least once more.

### **Speeches**

After the toasts have been completed, the President may open the floor to speeches by special guests and senior members of the ship.

Special presentations may also be made at this time. The President may allow the members of the mess to indulge in the open floor.

### **Dismissal**

Upon completion of all mess functions, the President shall close the meeting of the mess with a tap. All members will stand for the departure of the Head Table.

If a band is present, or a sound system is available, the head table leave to “*Heart of Oak*”

All members are then dismissed by the Vice-President of their table.

## **Behaviour/ Conduct**

The president may discipline any diner for misbehavior during the dinner.

S/He has two alternatives:

- Warn him/her; or
- Be fined.

## **Fines**

Fines are imposed for members who break, bend, or knowingly conceal a breach of mess rules.

Fines imposed upon a guest must be paid for by his/her host. However, if a guest is frequent to the mess then they may be held to the same rule as a general member (except for monetary fine).

Fines levied against an individual may vary from:

- Dismissal from the mess;
- Apology;
- Performance;
- Disclosure;
- Warning; and
- Or any other fine deemed acceptable by the President.

## **Bandmaster and Chief Cook**

If the band is in attendance at dinner, it is customary for the president to invite the bandmaster and, optionally, the chief cook to join him/her in a glass of port after the toasts have been drunk. A chair is placed beside the president for the bandmaster/chief cook when the invitation is issued.

## **Conversation**

There are no ranks or titles in the mess. All members present address each other as: Mister, Miss, or Misses. Only the President and Vice-Presidents will be addressed by title.

No member shall engage in conversation with the Head Table or the opposite table. Members shall only converse with those across, beside, and diagonal from themselves.

Do not speak with food in the mouth or gesticulate with utensils in the hand. The conversation should be tactful, kind, responsive, brief and cheerful.

One never asks for anything which is not offered, such as butter, vinegar, or catsup, as this is a reflection on the dinner.

## **Actions**

Male members shall push in the chair of a female member sitting beside them.

The youngest member of the ships company will be chosen to be the honorary Captain for the duration of the mess dinner. S/he will be given the respect and title entitled to the position.

It is customary for guests to be introduced to the President prior to commencement

of the mess function.

No member shall put their elbows on the table during the course of eating.

Prior to departing from the mess, each member must ask for permission to depart from the President. If the President has already departed then the next senior member or officer present shall be asked.

Naval members never clink glasses during any toast or greeting. This custom comes from the old belief that “a glass that rings tolls the death of a sailor”. Instead, a sailor forwards the back of their hand with the glass in it.

No member shall clap in the mess. Diners shall rap the table lightly to express their opinion and solicitations.

**TABLE ARRANGEMENT**

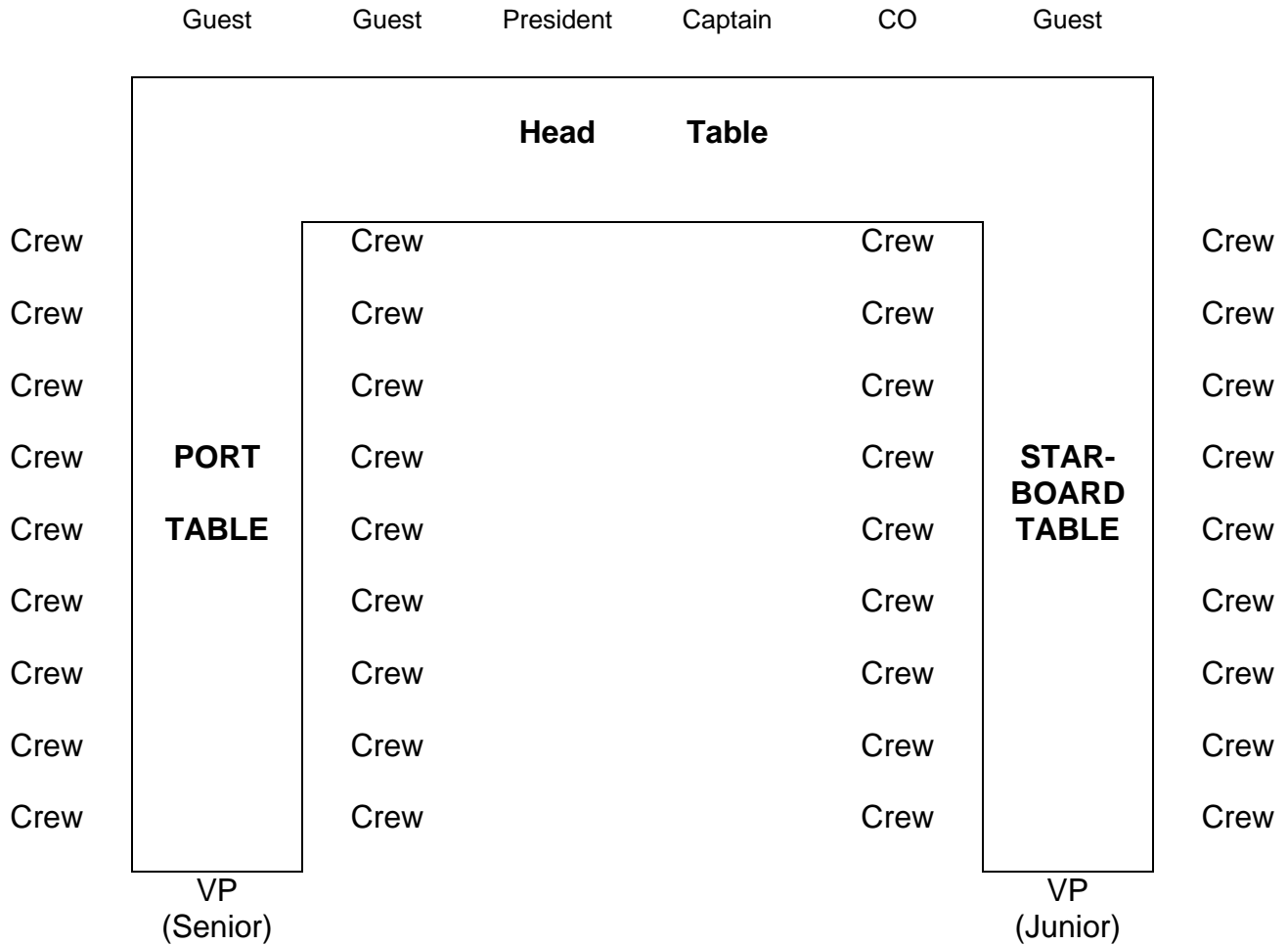



## PLACE SETTINGS

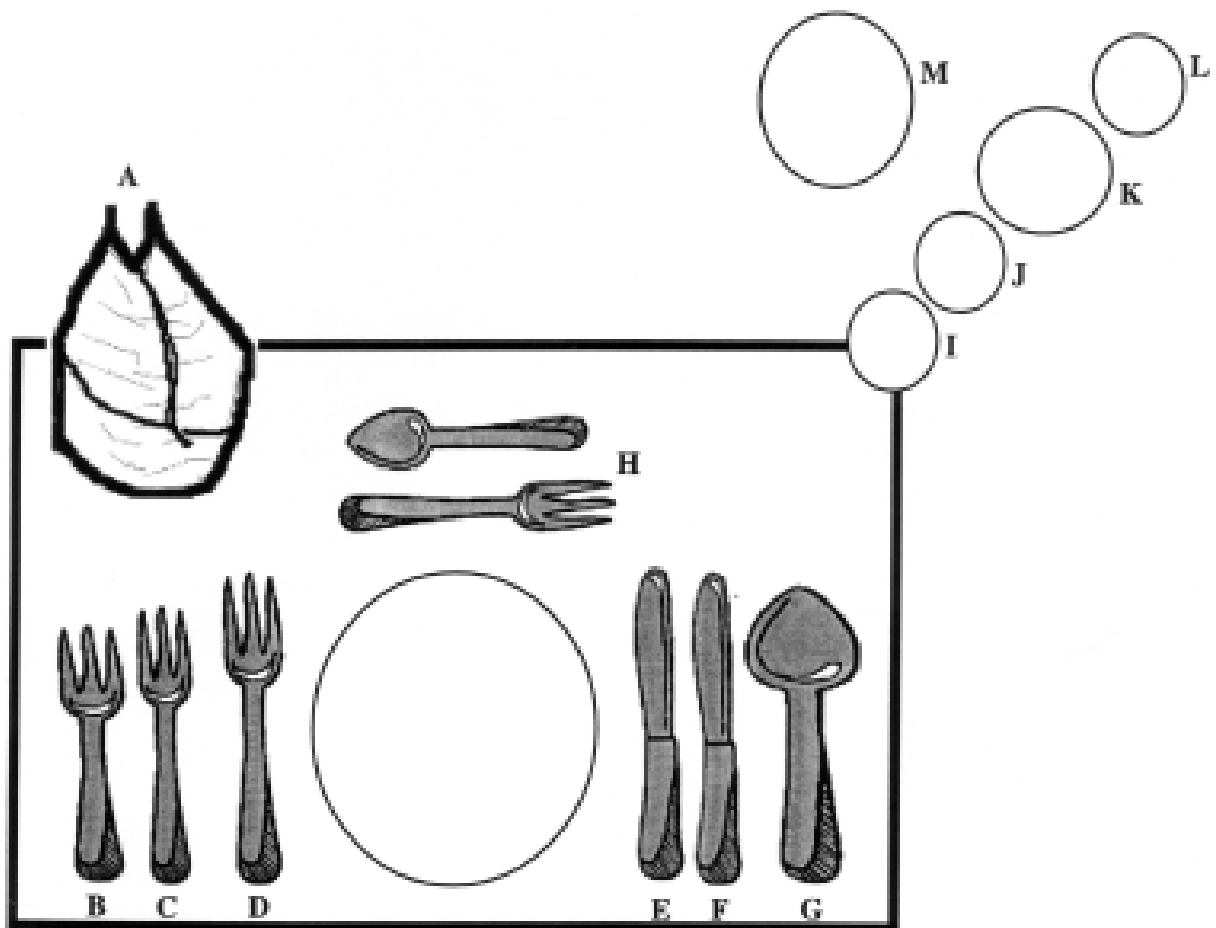

### Legend

- |    |                        |    |                 |
|----|------------------------|----|-----------------|
| A. | Napkin and Dinner Roll | H. | Dessert Service |
| B. | Salad Fork             | I. | Sherry Glass    |
| C. | Fish Fork              | J. | White Wine      |
| D. | Dinner Fork            | K. | Red Wine        |
| E. | Dinner Knife           | L. | Port            |
| F. | Fish Knife             | M. | Water Glass     |
| G. | Soup Spoon             |    |                 |

**TABLEWARE POSITIONS**

**Meal Not Completed**

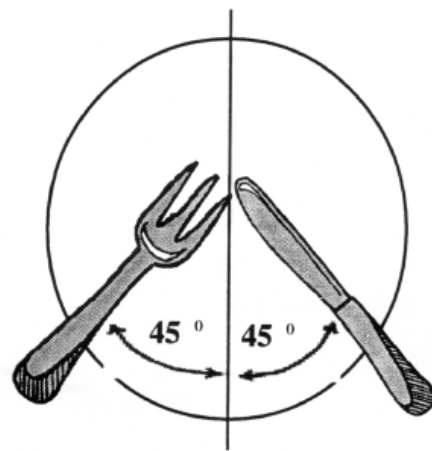
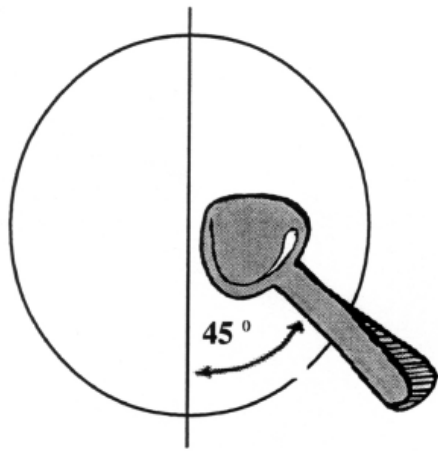

**Meal Completed**

**Soup Course**

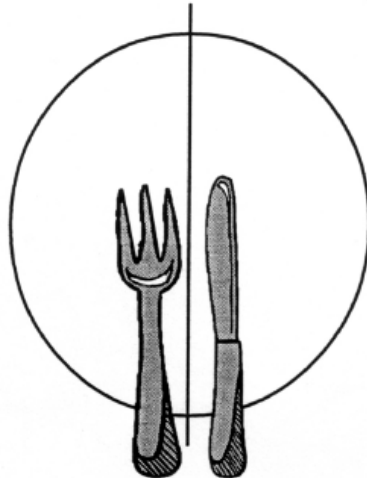
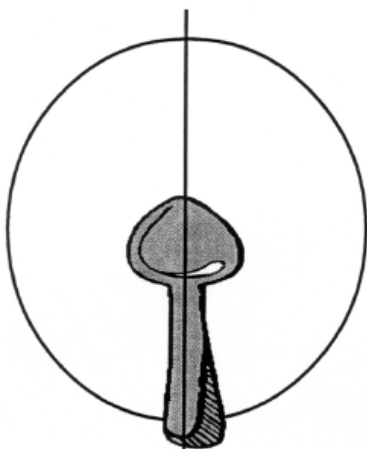

**Meat Course**

